

**Technical Support**



1.800.672.PAXT



[support@paxton-access.com](mailto:support@paxton-access.com)

Technical help is available: Monday - Friday from 02:00 AM - 8:00 PM (EST)  
Saturday from 04:00 AM - 08:00 AM (EST)

Documentation on all Paxton products can be found on our web site - <http://www.paxton-access.com/>

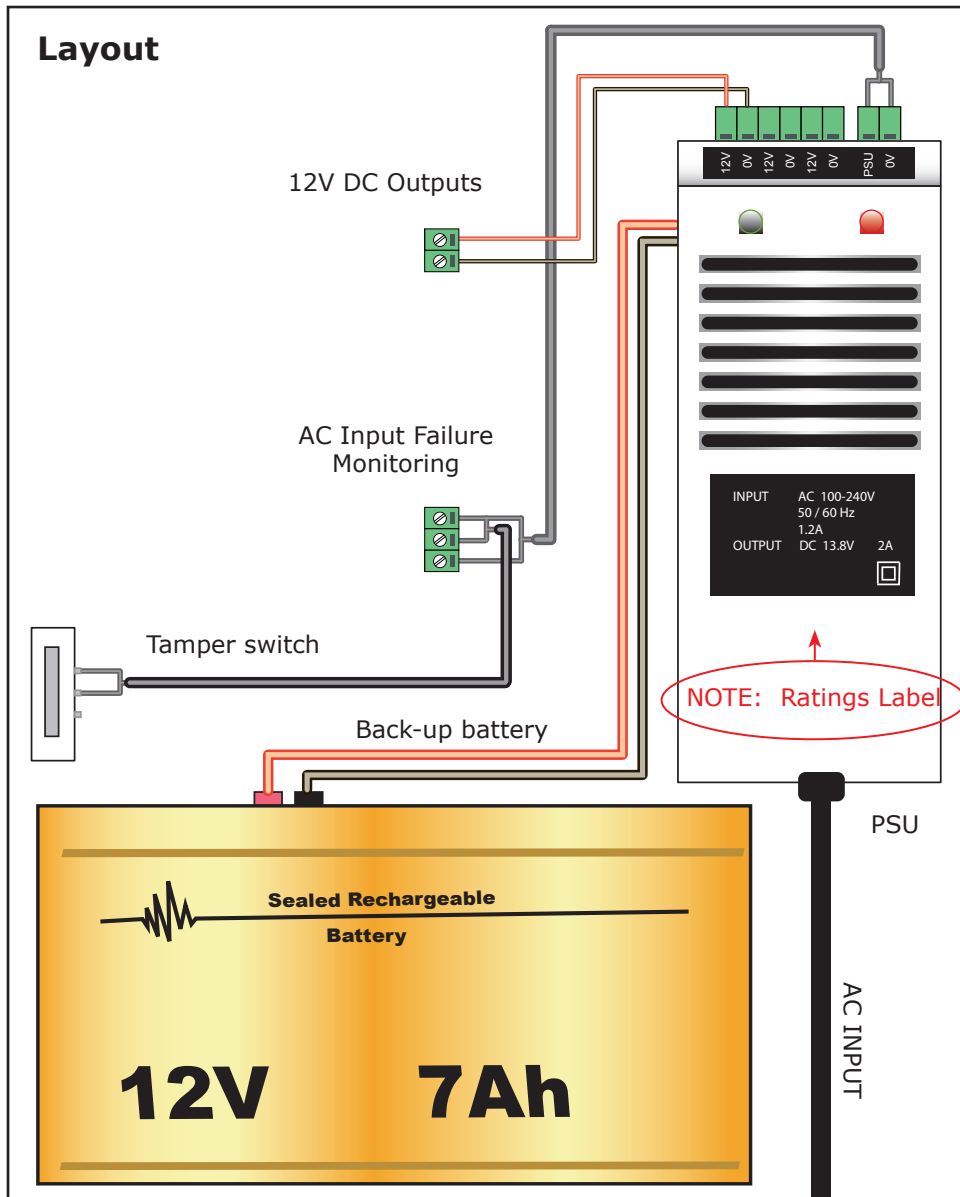

**Status Lights**

Green	This LED is on when the AC input supply is healthy.
Red	This LED is on when the AC input supply has failed - Power is being supplied by the battery.

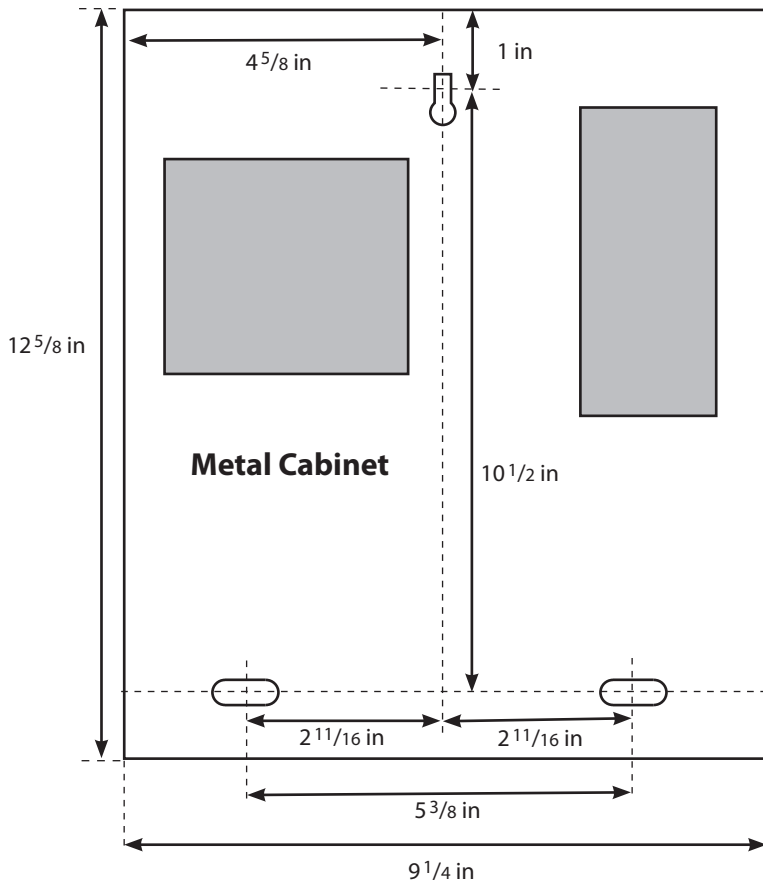

## Fitting

1. Screws and wall plugs are provided in a fitting kit. With reference to the diagrams, determine where the top, central mounting hole is required and drill a hole suitable for a No 8 wall plug in the surface chosen for the cabinet.
2. Tap in one of the wall plugs.
3. Put in one of the long screws, leaving a suitable gap to the wall surface in order to slot the cabinet over it.
4. Mark the hole positions for the lower 2 screws.
5. Remove the cabinet and drill the additional holes.
6. Tap in the 2 wall plugs and hang the cabinet back onto the top screw.
7. Secure the cabinet with the 2 lower screws.
8. Tighten the top screw.

This product is not suitable for retail sale. All warranties are invalid if this product is not installed by a competent person.

## AC Input Connection

A detachable figure 8 power cable is provided with the unit. This is pre-stripped at one end for connection to a fused spur.

Anchor points are supplied inside the case to secure the incoming 110V supply cable. (cable tidy/ties are provided) There are also 'knock-outs' in the case to allow convenient access for the cable.

Ensure that the supplied compression gland is used when passing the 110V supply cable through any holes in the cabinet.

The power supply is double insulated and requires no additional earth connection.

NOTE: The PSU's battery function will not work until this unit has first been connected to the mains supply. It is the loss of this supply that switches the unit to battery power.

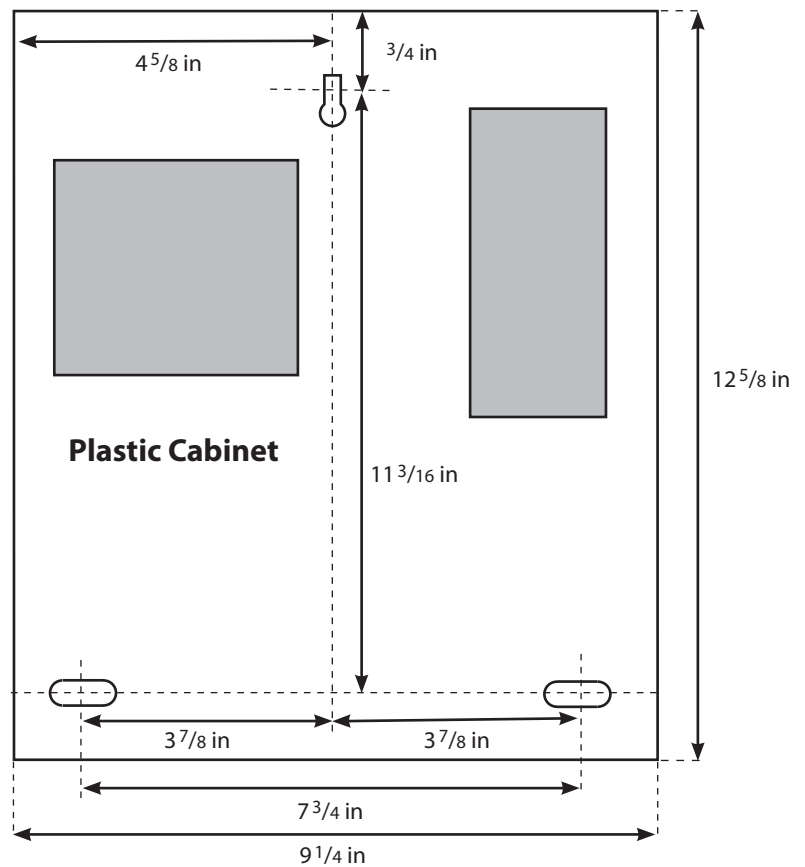

## Features

Fast/Trickle charge	The cabinet can accommodate a 7Ah battery (862-719)
Battery backup	The battery is continuously charged to keep it at maximum capacity.
Deep discharge protection	If battery voltage falls below 9.5V, it will automatically disconnect - Red Led goes out
AC supply failure (PSU)	This pair of volt free contacts goes open circuit if the mains power fails.
Tamper alarm	The tamper switch has volt free contacts that go open circuit if the lid is opened.

## Specifications

Environment	Min	Max	
Operating temperatures - all items	-20 °C (-4 °F)	+45 °C (+113 °F)	
Waterproof			No
PSU Electrical	Min	Max	
Output voltage	13V DC	13.8V DC	
Maximum load output current		2A	
Maximum battery charging current		1A	
Input supply voltage	100V AC	240V AC	+/- 10%
Input supply current		1.2A	
Input supply frequency	50 Hz	60 Hz	+/- 3 Hz
Dimensions	Width	Height	Depth
Metal Cabinet	9 1/4 in	12 5/8 in	3 1/8 in
Plastic Cabinet	9 1/4 in	12 5/8 in	3 1/8 in
Battery Compartment (Plastic Housing)	5 7/8 in	3 7/8 in	2 1/2 in

## WARNINGS

**The following warnings and instructions MUST be adhered to. Read the instructions before installing and powering the equipment. Keep the instructions in a safe place for future reference.**

**RECEIVING INSPECTION-** Remove any traces of packing material from the unit as such debris may create a fire or shock hazard. Unpack the unit with care and inspect for transit damage. If damage is suspected, the unit must not be used or tested, but should be returned to Paxton Access Limited for investigation and the damage reported to the carrier.

**INSTALLATION-** Only qualified and trained personnel, familiar with this type of product and who fully understand these instructions should install, connect or test this equipment. There are no user serviceable parts within the PSU unit.

- The equipment is intended for indoor use only in dry locations.

- The installation must meet the requirements of National Wiring Regulations and EN60950-1. A readily accessible disconnect device shall be incorporated in the building wiring to include an appropriately rated circuit breaker with at least a 3.0mm contact gap.

**DISCONNECTION-** After switch off, all internal capacitors will discharge to safe levels within 60 seconds under normal conditions. Under fault conditions, charge may be held for much longer and suitable precautions should be taken before handling the unit.

## FCC Compliance

Class B digital devices.

This equipment has been tested and found to comply with the limits for a Class B digital device, pursuant to Part 15 of the FCC Rules. These limits are designed to provide reasonable protection against harmful interference in a residential installation. This equipment generates, uses and can radiate radio frequency energy and, if not installed and used in accordance with the instructions, may cause harmful interference to radio communications. However, there is no guarantee that interference will not occur in a particular installation. If this equipment does cause harmful interference to radio or television reception, which can be determined by turning the equipment off and on, the user is encouraged to try to correct the interference by one or more of the following measures:

- Reorient or relocate the receiving antenna.
- Increase the separation between the equipment and receiver.
- Connect the equipment into an outlet on a circuit different from that to which the receiver is connected.
- Consult the dealer or an experienced radio/TV technician for help.

Class A digital devices.

This equipment has been tested and found to comply with the limits for a Class A digital device, pursuant to part 15 of the FCC Rules. These limits are designed to provide reasonable protection against harmful interference when the equipment is operated in a commercial environment. This equipment generates, uses, and can radiate radio frequency energy and, if not installed and used in accordance with the instruction manual, may cause harmful interference to radio communications. Operation of this equipment in a residential area is likely to cause harmful interference in which case the user will be required to correct the interference at his own expense.